

TECHNICAL DATA

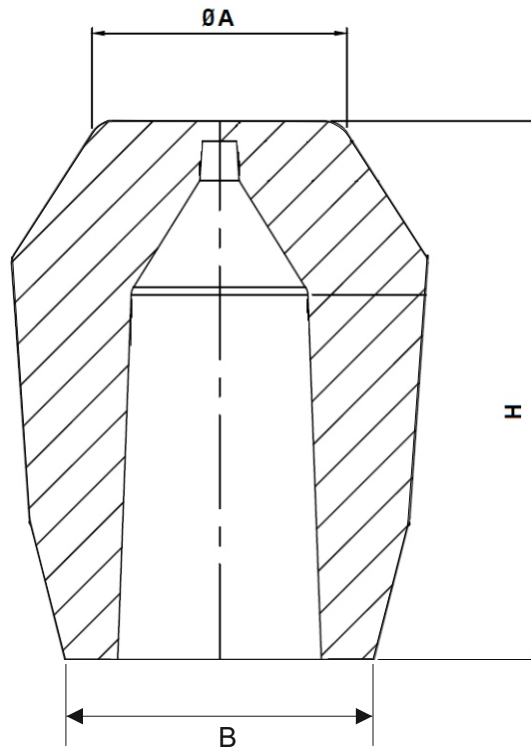

SIZE	Effective Modulus (cm)	VOLUME (CC)	Riser Weight (Kgs)	NOMINAL DIMENSIONS (mm)				
				A	B	C	H	h
SR - 4/17	1.30	40.00	0.29	49.00	54.00	17.00	85.00	17.00
SR - 8/21	1.50	84.00	0.61	64.00	72.00	21.00	112.00	21.00
SR - 10/21	1.75	99.00	0.72	52.00	63.00	21.00	110.00	21.00
SR - 12/23	1.85	126.00	0.92	90.00	83.00	23.00	130.00	34.00
SR - 13/23	2.15	137.00	1.00	77.00	79.00	23.00	114.00	34.00
SR - 16/23	2.20	160.00	1.17	100.00	83.00	23.00	120.00	34.00
SR - 19/23	2.50	195.00	1.42	119.00	93.00	23.00	140.00	32.00
SR - 24/25	2.75	236.00	1.72	93.00	96.00	25.00	138.00	34.00
SR - 28/25	3.00	284.00	2.07	100.00	98.00	25.00	138.00	34.00
SR - 68/30	3.75	627.00	4.58	120.00	124.00	30.00	175.00	35.00
SR - 77/30	4.15	726.00	5.30	141.00	124.00	30.00	205.00	35.00

Only minor variation to the extent of 0.5mm in diameter and 1 mm in height may occur.

Dimensions given above are nominal. Sleeves are precise on dimensions.



MARIKKO FOCHEM
(INDIA) PRIVATE LIMITED

AN ISO 9001 : 2015 CERTIFIED COMPANY